

**STACKABLE ON-OFF LS ELECTROVALVE**

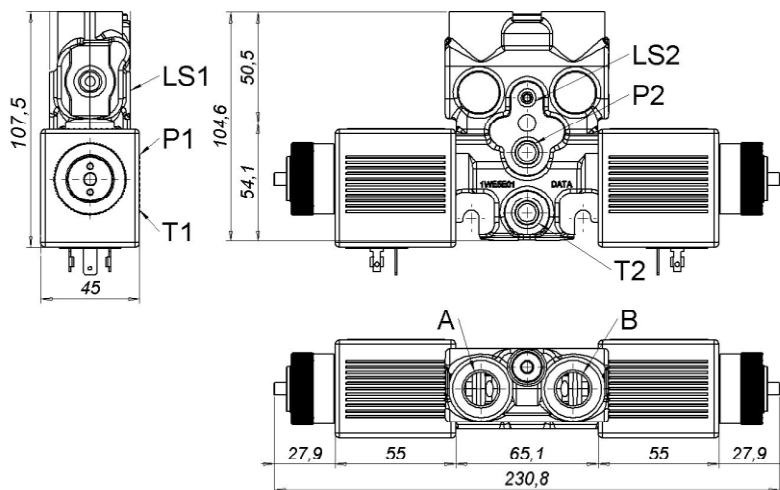
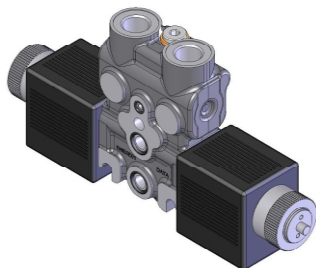

**Main features**

Max pressure	250 bar
Max pressure on T port	50 bar
Max flow	up to 40 l/min
Weight	1,6 Kg
Internal leakage	0,04 l/min at 100bar
Coil insulation	Class H
Electric connection	DIN 43650-A / ISO 4400
Protection class	IP 65 / DIN 40050
Duty cycle	ED 100%
Voltage required	+/- 10% nominal voltage
Manual Override	push
Standards	EN50081-1 / EN50082-2 (89/336 CEE electromagnetic comp.) 73/23/CEE / 96/68/CEE (low voltage)

**Spare part code**

- SD02** — Stackable directional on-off valve
- E2** — Spool configuration: see table below
- X** — Flow [lpm]
- TPLS** — Top Port with Load Sensing
- 24DC** — Supply voltage: 12VDC or 24VDC
- — Options: - = std

**Spool**



**Hydraulic scheme**

